

Children's Apparel Safety



Topics

- 1. Consumer Product Safety Commission Overview**
- 2. Health Canada**
- 3. Children's Apparel Potential Hazards**
 - Flammability**
 - Small Parts, Sharp Edges, Sharp Points**
 - Abuse Testing**
- 4. Garment Construction Requirements (drawstrings, fasteners, zippers, decorations, etc.)**
- 5. Restricted & Hazardous Substances**
- 6. Consumer Product Safety Improvement Act**
- 7. Wal-Mart's Children's Product Safety Standards**



CONSUMER PRODUCT SAFETY COMMISSION (CPSC)

WHO THEY ARE

The Consumer Product Safety Act is a law enacted by Congress in 1972. Under this law the CPSC was created and directed to “protect the public against unreasonable risks of hazards and deaths associated with consumer products.

WHAT THEY DO

CPSC works to reduce the risk of hazards and deaths from consumer products by:

- Developing voluntary standards with industry**
- Issuing and enforcing mandatory standards**
- Banning products**
- Conducting research on potential product hazards**
- Informing and educating consumers**



CONSUMER PRODUCT SAFETY COMMISSION (CPSC)

The CPSC has authority to recall products and also provides direction for manufacturers to initiate their own product recalls.

Products are recalled when they are identified as presenting a significant risk to consumers either because the product may be defective or violates a mandatory standard issued by CPSC.

Current and historical consumer product recalls can be found on the CPSC website:

<http://www.cpsc.gov/cpscpub/prerel/prerel.html>



Health Canada

WHO THEY ARE

Health Canada is the Federal department responsible for helping Canadians maintain and improve their health.

WHAT THEY DO

Health Canada helps protect the Canadian public by researching, assessing and collaborating in the management of the health risks and safety hazards associated with the many consumer products that Canadians use everyday. Health Canada is actively involved in injury prevention by:

- **Supporting the development of safety standards and guidelines.**
- **Enforcing legislation by conducting investigations, inspections, seizures and prosecutions.**
- **Testing and conducting research on consumer products.**



Health Canada

- n **Providing importers, manufacturers and distributors with hazard and technical information.**
- n **Publishing product advisories, warnings and recalls.**
- n **Promoting safety and the responsible use of products.**

Health Canada recalls are initiated by an importer or a manufacturer after becoming aware that the product is or may have a safety concern. Health Canada works cooperatively with companies to ensure the effective and efficient removal of hazardous products from the marketplace.

Current and historical consumer product recalls can be found on the Health Canada website.

<http://cpsr-rspc.hc-sc.gc.ca/PR-RP/home-accueil-eng.jsp>

CHILDREN'S APPAREL POTENTIAL HAZARDS

Children's apparel can present unnecessary risks of injury when poorly designed or constructed. Some of the hazards associated with children's clothing are listed below.

- **FLAMMABLE FABRICS**
- **CHILDREN'S SLEEPWEAR FLAMMABILITY**
- **DRAWSTRING, CORDS & TIES**
- **SMALL PARTS**
- **SHARP EDGES**
- **SHARP POINTS**
- **FLOAT THREADS & THREAD ENDS**
- **TOXIC SUBSTANCES**

Federal and state regulations have been developed to help reduce the risk for injury from these recognized hazards. Wal-Mart has also implemented additional apparel design requirements based on CPSC recall data and best industry practice to help minimize risk of injury to children.

Corresponding Age for USA Children's Apparel Sizes

The risk of injury from potential hazards are different depending on the age of the child. The table below shows the corresponding age that is applied to apparel size for Wal-Mart USA.

| Size | Age |
|------------------------|----------------------|
| 0 – 9M | Under 1 year |
| 12M – 5T | 12M to Under 3 yrs |
| Girls 4-6X / Boys 4-7 | 3 yrs to Under 8 yrs |
| Girls 7-16 / Boys 8-18 | 8 yrs and up |

Corresponding Age for Canada Children's Apparel Sizes

The risk of injury from potential hazards are different depending on the age of the child. The table below shows the corresponding age that is applied to apparel size for Wal-Mart Canada.

| Size | Age |
|-------------------------|----------------------|
| 0 – 9M | Under 1 year |
| 12M – 3X | 12M to Under 3 yrs |
| 4-6X | 3 yrs to Under 6 yrs |
| 7-16 Girls 7-18 Boys | 7 yrs and up |

Flammability of Clothing Textiles - USA

USA Wearing Apparel Flammability Testing

CFR TITLE 16 Part 1610 & 1611

Textile wearing apparel must comply with State and/or Federal regulations including reasonable and representative testing as required by CFR Title 16, Part 1610, Standard for the Flammability of Clothing Textiles, and must be classified as:

Class 1: Normal Flammability

Wearing apparel constructed of vinyl plastic film must meet requirements of 16 CFR 1611 Standard for the Flammability of Vinyl Plastic Film.

- Wearing apparel includes costumes or articles of clothing for children or adults.
- Most hats, gloves, footwear and interlinings are not required to meet this standard.

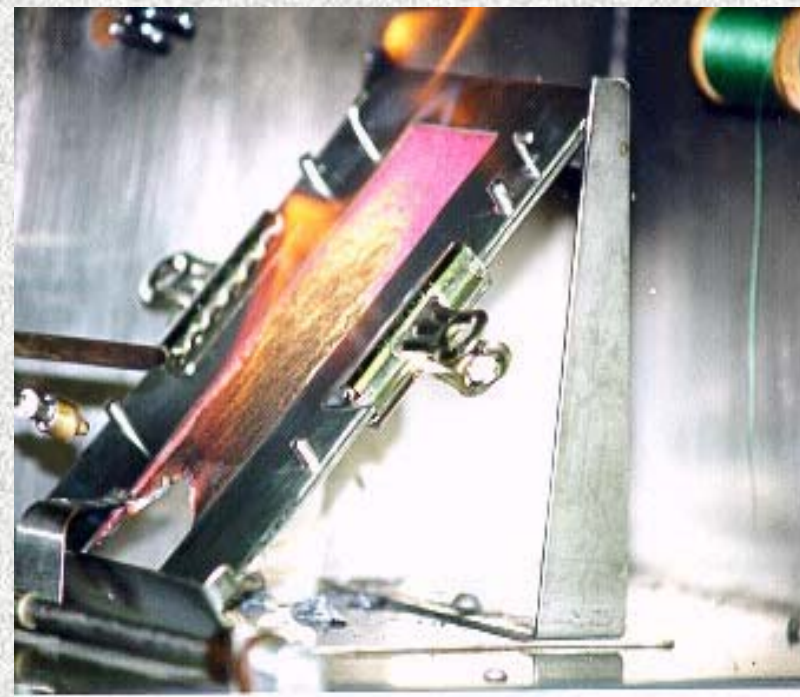

USA Wearing Apparel Flammability Testing CFR TITLE 16 Part 1610

What Fabrics are Covered?

Plain surface fabrics that must be tested include:

Fabrics that weigh less than 2.6 oz/sq yd (88.14 gm/sq m) (based on 16 CFR Part 1610 requirements)

OR

2.7 oz/sq yd (91.53 gm/sq m) to assure compliance, unless excluded due to fiber content.

USA Wearing Apparel Flammability Testing

CFR TITLE 16 Part 1610

What Fabrics are exempt?

Fabrics that are **exempt** from apparel flammability testing include:

- **Plain surface fabrics, regardless of fiber content, weighing 2.6 oz / sq yd (88.14 gm/sq m) or more (based on 16 CFR Part 1610 requirements). However, in order to assure compliance with 16 CFR Part 1610, it is recommended that only fabrics weighing 2.7 oz / sq yd (91.53 gm/sq m) or more should be exempt.**
- **All fabrics, plain surface or raised fiber regardless of weight made entirely from any of the following fibers or entirely from any combination of the following fibers:**

**Acrylic
Polyester**

**Olefin
Nylon**

**Modacrylic
Wool**

USA Wearing Apparel Flammability Testing

CFR TITLE 16 Part 1611 - Recall

HAZARD: The vinyl capes fail to meet the flammability standard for vinyl plastic film, posing fire and burn hazards to consumers.

NEWS from CPSC

U.S. Consumer Product Safety Commission

Office of Information and Public Affairs

Washington, DC 20207

FOR IMMEDIATE RELEASE
October 31, 2006
Release #07-021

Firm's Recall Hotline: (800) 547-0359
CPSC Recall Hotline: (800) 638-2772
CPSC Media Contact: (301) 504-7908

Family Dollar Recalls "Creepy Cape" Costumes Due to Flammability Hazard

WASHINGTON, D.C. - The U.S. Consumer Product Safety Commission, in cooperation with the firm named below, today announced a voluntary recall of the following consumer product. Consumers should stop using recalled products immediately unless otherwise instructed.

Name of Product: "Creepy Cape" Halloween Costumes

Units: About 120,000

Importer: TONY Development & Manufacturing (USA), of Montclair, N.J.

Retailer: Family Dollar Inc., of Matthews, N.C.

Hazard: These vinyl capes fail to meet the standard for the flammability of vinyl plastic film, posing fire and burn hazards to consumers.

Incidents/Injuries: None reported.

Description: The recall involves 40-inch black vinyl capes with a stand-up collar. A white sticker on the collar of the cape reads, "FLAME RETARDANT PVC" and "MADE IN CHINA." The packaging shows a green-skinned vampire wearing a black cape. Writing on the packaging includes "CREEPY CAPE," "Ages 6 To 60," and "NO. 53600."

Sold at: Family Dollar stores nationwide from August 2005 through October 2006 for about \$2.

Manufactured in: China

Remedy: Consumers should stop using the recalled capes and return them to any Family Dollar store for a full refund.

Consumer Contact: For additional information, contact Family Dollar toll-free at (800) 547-0359 between 8:30 a.m. and 5 p.m. ET Monday through Friday, or visit the firm's Web site at www.familydollar.com

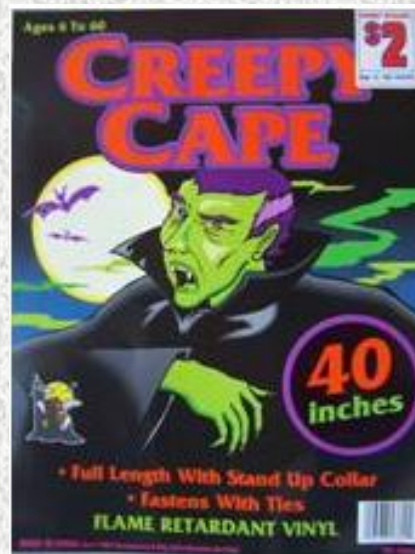

Flammability of Textiles - Canada

Canada Textile Flammability Testing CAN/CGSB-4.2 NO. 27.5

This test method is applicable to:

- **Textile fiber products including general textile products**
- **Children's sleepwear not covered by Item 40 Part II of the Hazardous Products Act**
- **Bedding**
- **Cribs**
- **Cradles**
- **Playpens.**

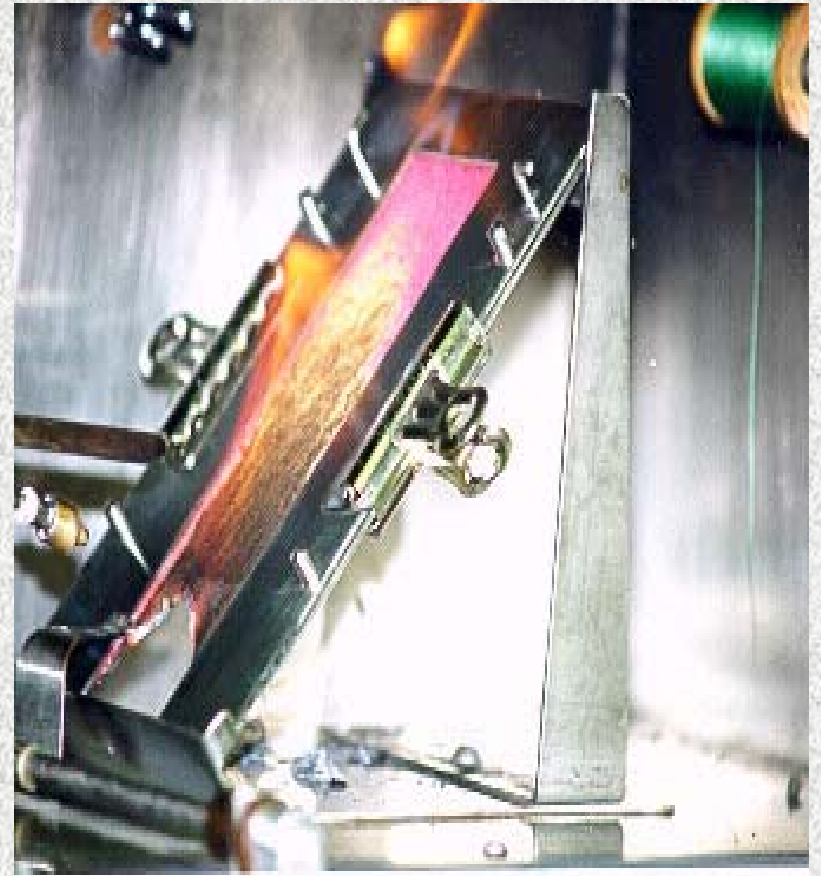

Sleepwear Flammability - USA

USA Children's Sleepwear Flammability CFR Title 16, Part 1615 & 1616

All children's sleepwear garments sized 0 - 20 must comply with any and all State and/or Federal guidelines, regulations, and laws, including but not limited to CFR Title 16, Part 1615 and 1616.

What is Sleepwear?

Children's sleepwear is any article of clothing, such as a nightgown, pajama, robe or loungewear, that is sized above 9 months to size 20 that is intended to be worn **primarily for sleeping or activities related to sleeping.**



If the packaging or any printed design on a children's garment suggests sleeping, it will be considered sleepwear, and must pass testing to comply with the requirements set forth in CFR Title 16, Part 1615 and 1616.

USA Children's Sleepwear Flammability

Loungewear

Loungewear that suggests sleeping, by packaging, printed design or garment construction is viewed as sleepwear and must be in compliance with the tight fitting requirements or the flammability requirements for 16 CFR 1615 and 1616.



The following photos depict how quickly a flame can spread on a loose fitting cotton nightgown.



Start



30 sec



60 sec



90 sec



120 sec



End

USA Children's Sleepwear Flammability - Recall

HAZARD: The sleepwear fails to meet the flammability standard, posing a risk of burn injury to children

NEWS from CPSC

U.S. Consumer Product Safety Commission

Office of Information and Public Affairs

Washington, DC 20207

FOR IMMEDIATE RELEASE
April 17, 2007
Release #07-156

Firm's Recall Hotline: (866) 902-2798
CPSC Recall Hotline: (800) 638-2772
CPSC Media Contact: (301) 504-7908

Disney Store Recalls Children's Footed Pajamas Due to Burn Hazard

WASHINGTON, D.C. - The U.S. Consumer Product Safety Commission, in cooperation with the firm named below, today announced a voluntary recall of the following consumer product. Consumers should stop using recalled products immediately unless otherwise instructed.

Name of product: Baby Einstein Caterpillar Sleepwear and Baby Einstein Duck Sleepwear

Units: About 200

Retailer: Disney Stores North America, of Pasadena, Calif., which is owned, and under a licensing agreement operated, by a subsidiary of The Children's Place Retail Stores Inc. of Secaucus, N.J.

Hazard: This sleepwear fails to meet the children's flammability standard, posing a risk of burn injury to children.

Incidents/Injuries: None reported.

Description: The recall involves footed pajamas made of 100 percent cotton. The sleepwear was sold in two styles including green with blue sleeves which has a caterpillar design on the front, and yellow with orange sleeves which has a duck design and "Quack! Quack!" printed on the front and duck beaks on the feet. "Baby Einstein" is printed on the back of the sleepwear. "Disney Store" is printed on a tag inside the pajamas. Only sleepwear in sizes 12 months and 18 months is included in this recall. Sleepwear sold in sizes 3, 6 and 9 months is not included in this recall.

Sold exclusively at: Disney Stores nationwide from April 2006 through May 2006 for about \$20.

Manufactured in: China

Remedy: Consumers should immediately stop using the recalled sleepwear and return it to any Disney Store for a full refund.

Consumer Contact: For additional information, contact Disney Store toll-free at (866) 902-2798 between 8:30 a.m. and 5 p.m. PT Monday through Friday.



Sleepwear Flammability - Canada

Canada Children's Sleepwear Flammability Hazardous Products Act, Schedule I, Part II, Item 40, Children's Sleepwear

The evaluation of loose-fitting children's sleepwear up to and including size 14X.

What is covered?

Children's nightgowns, nightshirts, dressing gowns, bathrobes, housecoats, robes, pajamas, and baby-doll pajamas.

What is NOT covered?

Sleepwear designed for use in a hospital, for infant's up to 7 kg, polo pajamas and sleepers.



Canada Children's Sleepwear Flammability - *Recall*

HAZARD: The sleepwear fails to meet the flammability standard, posing a risk of burn injury to children.

- The recalled sleepwear does not meet the design and flammability requirements for children's sleepwear under Canadian law.
- Loose-fitting children's sleepwear can contact ignition sources such as stove elements, candles, and matches more readily than tight-fitting sleepwear. When loose-fitting sleepwear is made with natural fibers such as cotton, they can burn rapidly, potentially resulting in severe burns to large areas of the child's body.



SMALL PARTS

Small Parts

What is a small part?

n ***A small part is any object that fits completely into the specially designed test cylinder that approximates the size of the fully expanded throat of a child under three years old.***

n ***If the component can fit entirely within the small parts cylinder, without being compressed, it is considered a potential choking hazard.***

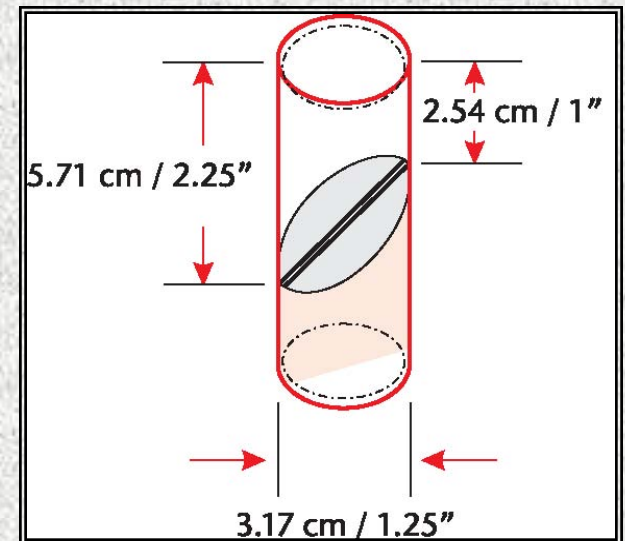

Small Parts

- n ***Small components that become detached from children's products can present choking, aspiration, or ingestion hazards to children under three years of age.***
- n ***Children's apparel sizes 0-5T (USA) and 0-6X (Canada) must not exhibit any detached hazardous small parts as received, or after being subjected to normal use and reasonably foreseeable abuse testing.***



Small Parts

Examples of small parts on Apparel include, but are not limited to:

- Snaps/Rivets
- Toggles
- Appliqués
- Buttons
- Stud Buttons
- Zipper Components
- Decorative labels
- Eyelets & Rivets
- Belt fastenings
- Hook & Loop Tape
- Dungaree Clip (Hasps) & Slider
- Pom-poms & Fringe
- Aglets (plastic sleeves)
- Bows and Rosettes
- Decorative & Functional Loops

Small Parts Labeling - USA

- **Sizes Girls 4-6X / Boys 4-7 must exhibit the choking hazard warning hangtag if the garment contains:**

A cord, tie, or belt made from metal chain

OR

Small part embellishments (beads, jewels, metal studs, rhinestones, etc.)

- **These types of components are not allowed for use on garments intended for children under 3 years as they present a greater risk of becoming detached.**

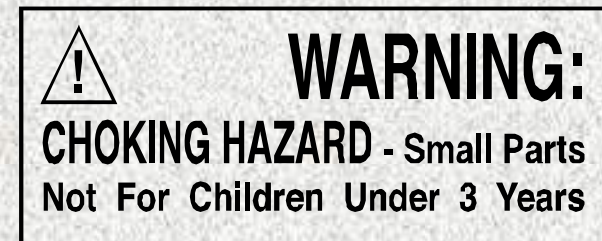

Sizes 0-5T must NOT include the choking hazard warning hangtag.

Small Parts Labeling - Canada

- **Sizes 4-6X must exhibit the choking hazard warning hangtag (in both English & French) if the garment contains:**

Small part embellishments such as beads, jewels, sequins, rhinestones, etc.

- **These types of components are not allowed for use on garments intended for children under 3 years as they present a greater risk of becoming detached.**

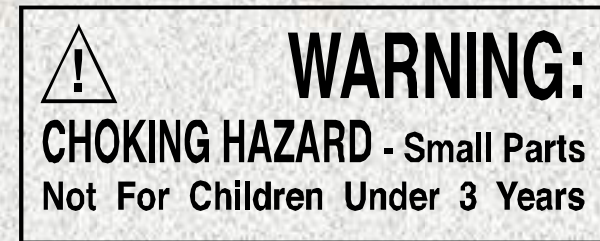

Sizes 0-3X must NOT include the choking hazard warning hangtag.

USA SMALL PARTS - RECALL

Hazard: The pom poms and snaps on the outfits can detach, posing a choking hazard to young children.

Recall Alert

U.S. Consumer Product Safety Commission

Office of Information and Public Affairs

Washington, DC 20207

April 24, 2008
Alert #08-563

Infant Santa Outfits Recalled by Avon Products Due to Choking Hazard; Sold in Puerto Rico and U.S. Virgin Islands

The following product safety recall was voluntarily conducted by the firm in cooperation with the CPSC. Consumers should stop using the product immediately unless otherwise instructed.

Name of Product: Infant Santa Outfits

Units: About 17,000

Distributor: Avon Products Inc., of New York, N.Y.

Importer: MacSwed Inc., of New York, N.Y.

Hazard: The pom poms on the 2006 and 2007 outfit and the snaps on the 2007 outfit can detach, posing a choking hazard to young children.

Incidents/Injuries: None reported.

Description: This recall involves the 2006 and 2007 Santa Outfits with RN# 120273. The 2006 Santa Outfit includes a red hat decorated with a white pom pom and a red one-piece suit with white collar and cuffs, and stitched black belt and boots. The 2007 Santa Outfit includes a red hat decorated with a white pom pom, a red and white-striped bodysuit with a Santa Claus face on the chest, red overall pants with suspenders, and a red bib with Santa Claus face on top. Two snaps fasten the bodysuit at the shoulder and three snaps fasten the suit between the legs. The outfits were sold in sizes 3-18 months. "RN# 120273" is printed on the care label.

Sold through: Avon Independent Sales Representatives in Puerto Rico and the U.S. Virgin Islands from August 2006 through November 2007 for about \$15 for the 2006 outfit and about \$20 for the 2007 outfit.

Manufactured in: China

Remedy: Consumers should immediately take the 2007 outfit away from children and contact Avon for a refund. Consumers with the 2006 outfit should immediately remove the pom-pom from the hat.

Consumer Contact: For additional information, contact Avon at (888) 993-9903 between 9 a.m. and 6 p.m. ET Monday through Friday, or visit the firm's Web site at www.avon.com



Canada Small Parts - Recall

HAZARD: Small objects may pose a choking hazard to infants and small children.

- Health Canada received complaints of two snap buttons closest to the neck coming off this garment.



SHARP EDGES

Sharp Edges

- n Hazardous sharp edges on children's products can present potential skin laceration hazards to children of all ages.
- n All size ranges of children's apparel must not exhibit hazardous sharp edges as received and after being subjected to normal use and reasonably foreseeable abuse testing.

Potential Sharp Edge on a Belt Buckle



SHARP POINTS

Sharp Points

Hazardous sharp points on children's products can present skin Puncture and skin laceration hazards to children.

There are two types of sharp points, that may be present:

Functional and Non-Functional

Non-Functional Sharp Points

Children's apparel must NOT exhibit any hazardous *Non-Functional Sharp Points* as received and after being subjected to normal use and abuse testing.

Examples of *Non-Functional Sharp Points*

Fastener Tape - Edges Not Rounded

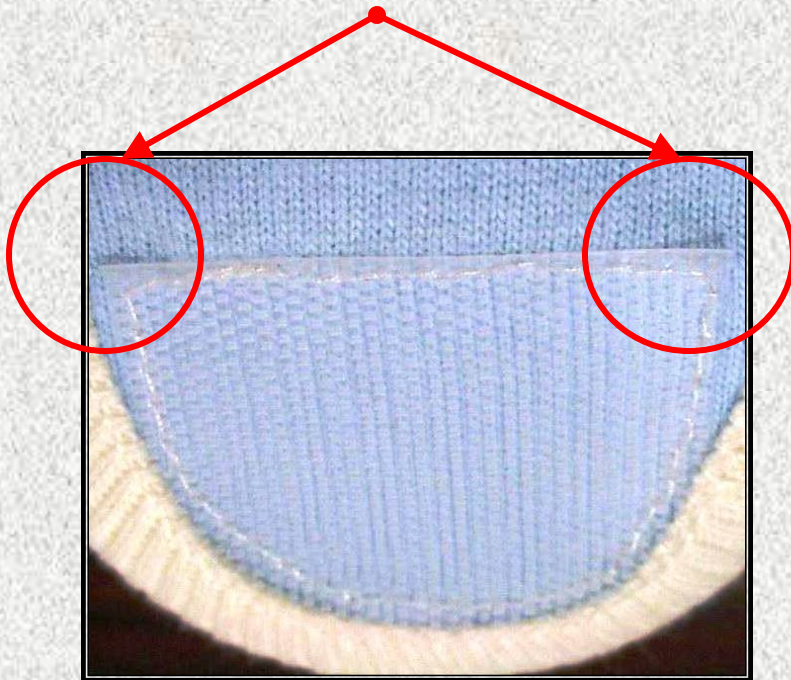

Zipper Stop - Mold Flash Not Trimmed

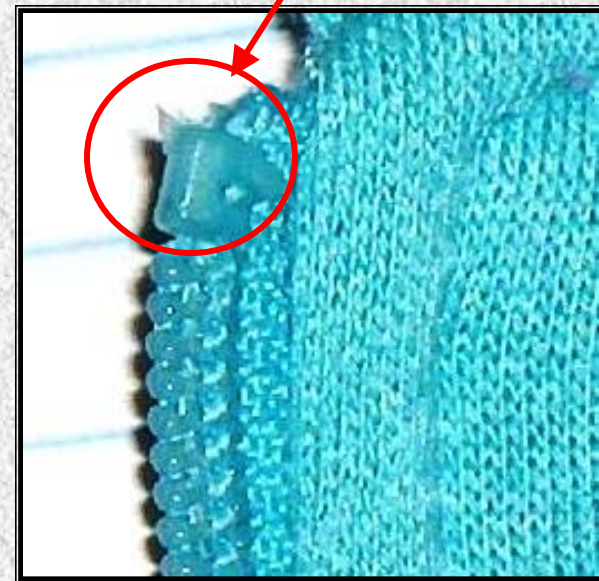

Non-Functional Sharp Points

Examples of *Non-Functional Sharp Points*

Sewing Needle - Left in the product

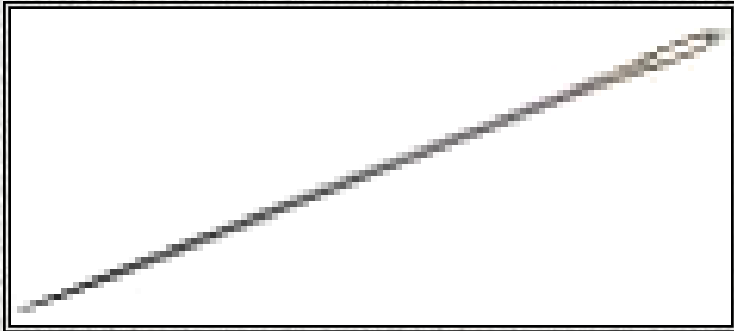

Press Fastener – Protruding Prong



Functional Sharp Point (Apparel)

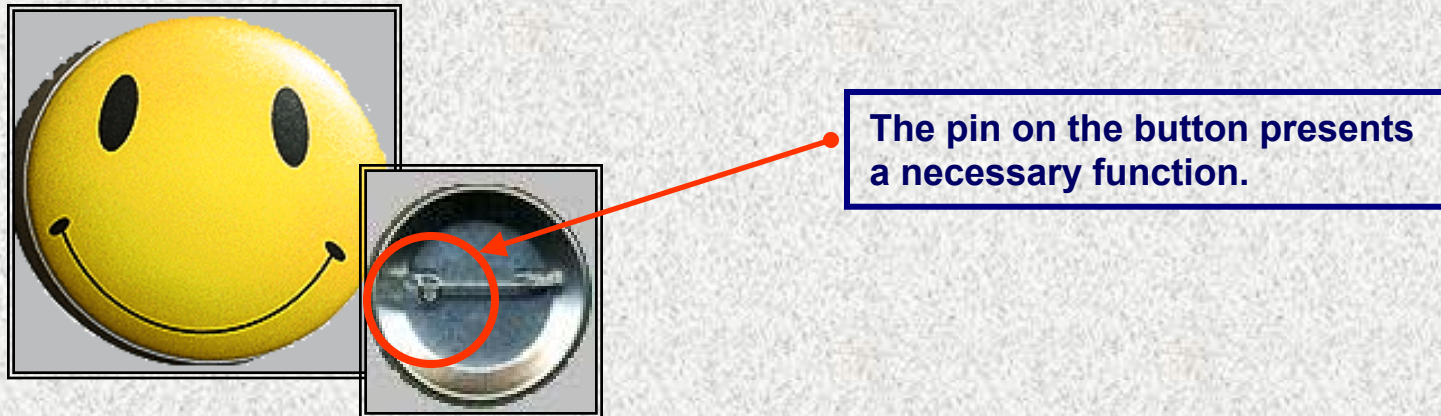

The pin on the button presents a necessary function.

- n. ***Functional Sharp Points*** are NOT allowed in the USA for Girls sizes 0-6X and Boys sizes 0-7 and in Canada for Girls / Boys sizes 0-6X.

- n. ***Functional Sharp Points*** are allowed in the USA for Girls sizes 7-20 and Boys sizes 8-20 and in Canada for Girls / Boys sizes 7-18.

Sharp Point - Recall

Hazard: A wire can protrude through the fabric posing a laceration hazard to consumers.

Recall Alert

U.S. Consumer Product Safety Commission

Office of Information and Public Affairs

Washington, DC 20207

April 17, 2007
Alert #07-541

DreamWorks Animation SKG Recalls Shrek Headbands Due to Injury Hazard; Giveaway Product Distributed To Pepsi Employees

The following product safety recall was voluntarily conducted by the firm in cooperation with the CPSC. Consumers should stop using the product immediately unless otherwise instructed.

Name of Product: Shrek Ears Headbands

Units: About 6,000

Distributor: Paramount Pictures Corp., of Hollywood, Calif., under contract with DreamWorks Animation SKG, of Glendale, Calif.

Hazard: A small wire can protrude through the fabric of the ears on these headbands, posing a risk of cuts to consumers.

Incidents/Injuries: None reported.

Description: The item is a plastic headband covered in bright green fabric with two ears similar to the character Shrek from the DreamWorks film series. A tag attached to one of the ears reads "DREAMWORKS" and "THE THIRD," and shows the top of the Shrek character's head.

Distributed by: Paramount Pictures to Pepsi Bottlers which distributed the headbands as a giveaway product to their employees from February 23, 2007 through April 1, 2007. The recall does not include any ear headbands purchased, or distributed free of charge, before February 23, 2007 and after April 1, 2007.

Manufactured in: China

Remedy: Stop using the recalled headbands immediately and call for information on returning the headbands to receive a free replacement item.

Consumer Contact: Consumers who received the headbands through Pepsi Bottlers should call (800) 782-6116 between 8 a.m. and 8 p.m. ET Monday through Friday.

Media Contacts: Dave DeCecco, PepsiCo., (914) 253-2655, and Rich Sullivan, DreamWorks Animation SKG, (818) 695-3521



ABUSE TESTING

Abuse Testing – Apparel

Torque Test

The torque test is applied to functional or decorative components which are rigidly assembled or attached (e.g. zipper pull, or similar decorations) and that the child can grasp with at least the thumb and forefinger, or the teeth.

The amount of torque applied is determined by the size range, as shown in the table below.

| Apparel Size | Torque Applied |
|--|------------------|
| 0 to 9M – USA 0 to 18M - Canada | 2 +/- 0.2 in-lbs |
| 12M-5T – USA 24M-36M - Canada | 3 +/- 0.2 in-lbs |
| Girls 4-6X – USA Boys 4-7 – USA 3x-6x – Canada | 4 +/- 0.2 in-lbs |

Upon completion the component is examined for small parts, and sharp edges and points.



Abuse Testing – Apparel

Tension Test

- *The tension test is applied to functional or decorative components on children’s apparel sizes 0-5T (USA) and sizes 0-6X (Canada).*
- *Any decorative or functional component that a child can grasp with at least the thumb and forefinger, or the teeth shall be subjected to this test.*
- *The amount of tensile force is 15 lbs for all components requiring the test.*



Upon completion the component is examined for small parts, and sharp edges and points.

DRAWSTRINGS, CORDS & TIES

Drawstrings, Cords & Ties

- Drawstrings, cords and ties can cause death by catching on bus doors or handrails, playground equipment, and cribs.
- Drawstrings, cords and ties at the waist, hood, neck, ankle or wrist areas can catch in small gaps or on bolts.
- Drawstrings, cords and ties with attachments such as knots, or toggles are most likely to get caught.

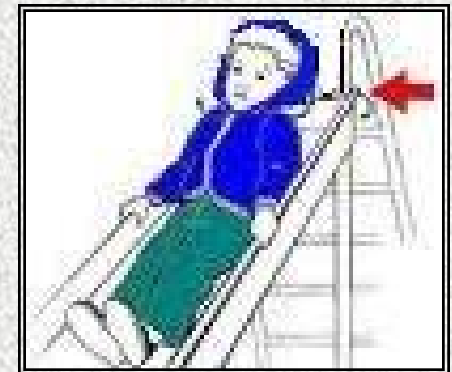
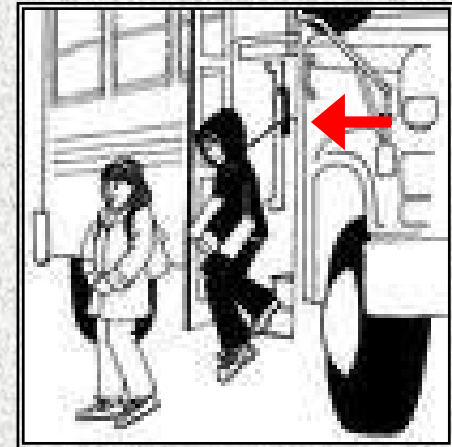

CPSC has issued guidelines for drawstrings on children's clothing and the states of New York and Wisconsin have regulations which ban the use of certain drawstrings on children's clothing

State Drawstring Regulations

New York Law (NY CLS Gen. Bus §391.b)

BANS:

1. *Children's Garments sized 0-12 with hood or neck opening drawstring*
2. *Children's Upper Garments sized 2T -16 with drawstring at the bottom opening UNLESS the drawstring is no more than 3 inches AND attached at midpoint.*
3. *Children's Garments sized 2T -16 with a drawstring at the waist UNLESS the drawstring measures no more than 3 inches AND is attached at midpoint.*
4. *Drawstrings with toggles, knots or any attachments at free ends are banned.*



State Drawstring Regulations

Wisconsin State Law (ATCP 139.055)

BANS:

1. Children's clothing sizes 0-16 with a drawstring in the neck area.
2. Children's Upper Outerwear sizes 0-16 with a drawstring in the waist or at the bottom of the garment...

UNLESS

The drawstring measures no more than 3 inches.

AND

The drawstring does not have toggles, knots etc at the free ends.

AND

The drawstring is sewn at midpoint of the channel.

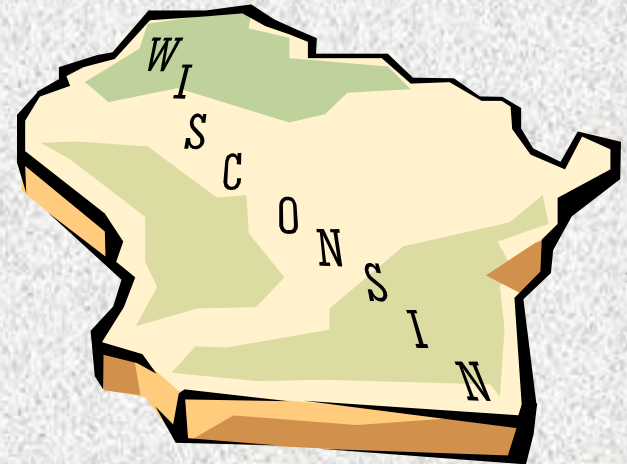

Drawstrings, Cords and Ties

n Drawstrings, cords, and ties are not allowed in some areas of a garment, and are allowed in others with maximum length restrictions.

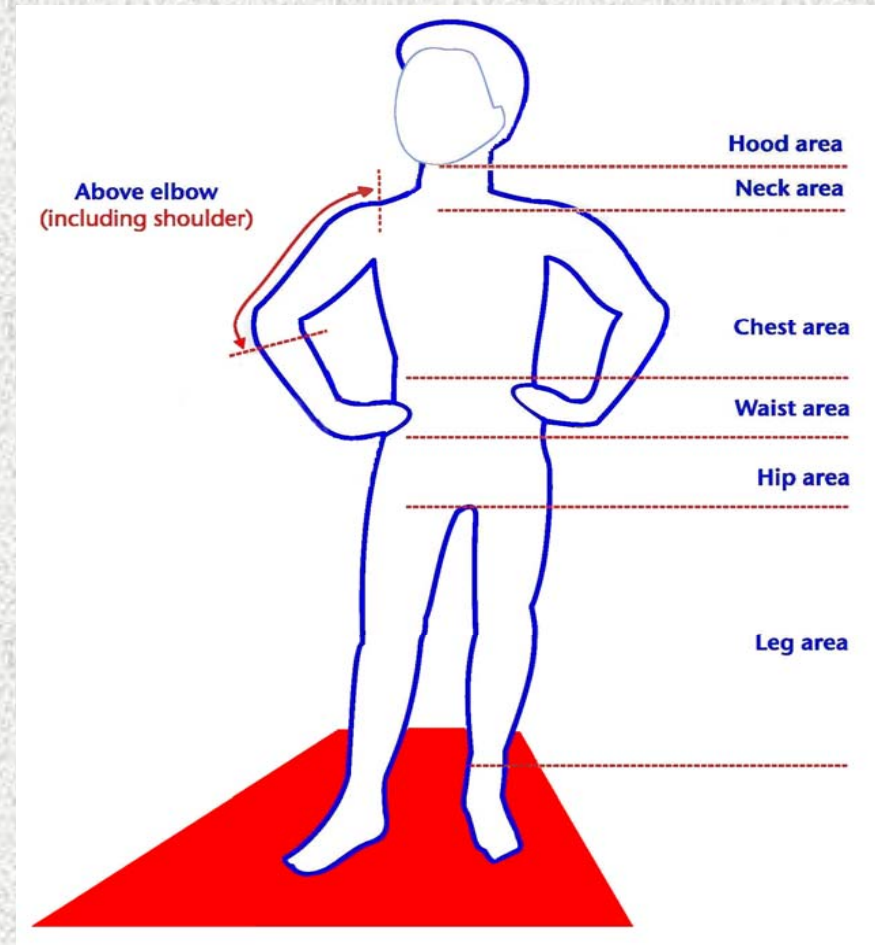

Drawstrings, Cords and Ties – General Requirements

- n ***The free ends of all drawstrings, cords and ties must NOT be secured with a knot or equivalent (beads, toggles, pom-poms, etc).***
- n ***Drawstrings must be secured with a bartack to prevent pulling out of the garment.***



Drawstrings, Cords and Ties – Neck and Hood Area

- n Drawstrings and Functional Cords and Ties are not allowed in the hood and neck area.***
- n Decorative cords and ties, when allowed, can only be located on the hood at the base of the front opening and cannot be constructed of elastic.***

Drawstrings, Cords and Ties - Other Areas

n *Drawstrings, cords and ties of any type are NOT allowed:*

- At the hems of children's apparel that finish at or below the ankle.

OR

- At the ends of sleeves that finish below the elbow.

Drawstrings, Cords and Ties – Metal Chain Requirements

- n Cords and ties made from metal chains are ***NOT allowed*** for Sizes 0 - 5T (USA) and 0 – 6X (Canada).
- n For USA Sizes 4 and up, cords, ties or belts made from metal chain must breakaway under the weight of the child.
- n For USA Sizes Girls 4-6X / Boys 4-7, cords, ties or belts made from metal chain must exhibit the Choking Warning Hangtag.

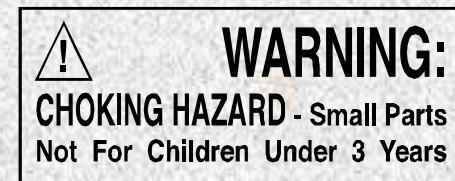

Drawstrings, Cords and Ties – Adjustable Waistbands

- n **Adjustable waistbands must be secured to the garment with a bartack to prevent the band from being pulled out.**



Drawstring - Recall

Hazard: The garments have a drawstring through the hood, posing a strangulation hazard to children.

NEWS from CPSC

U.S. Consumer Product Safety Commission

Office of Information and Public Affairs

Washington, DC 20207

FOR IMMEDIATE RELEASE
February 24, 2006
Release #06-097

Firm's Recall Hotline: (866) 871-9978
CPSC Recall Hotline: (800) 638-2772
CPSC Media Contact: (301) 504-7908

Next Marketing Inc. Recalls Youth Hooded Fleece with Drawstring for Strangulation Hazard

WASHINGTON, D.C. - The U.S. Consumer Product Safety Commission, in cooperation with the firm named below, today announced a voluntary recall of the following consumer product. Consumers should stop using recalled products immediately unless otherwise instructed.

Name of Product: Youth Hooded Fleece with Drawstring

Units: About 22,000

Manufacturer: Next Marketing Inc., of Wabash, Ind.

Hazard: The garments have a drawstring through the hood, posing a strangulation hazard to children. In February 1996, CPSC issued [guidelines](#) to help prevent children from strangling or getting entangled on the neck and waist by drawstrings in upper garments, such as jackets and sweatshirts.

Incidents/Injuries: None reported.

Description: The recalled youth hooded fleece garments have drawstrings. They were sold in a variety of colors and many of them have the names of colleges and universities printed or embroidered on them. A sewn-in tag reads, "Lil Fan" or "LF 2."

Sold at: Web retailers, college book stores and department stores nationwide from September 2003 through December 10, 2005 for about \$15.

Manufactured in: China and Pakistan

Remedy: Consumers should remove or cut the drawstrings to eliminate the hazard, or return the garment to the store where purchased for help in removing the drawstring.

Consumer Contact: For additional information, contact Next Marketing Inc. toll-free at (866) 871-9978 between 8 a.m. and 5 p.m. ET Monday through Friday, or visit the firm's Web site at <http://www.nextinc.net/productrecalls.html>

Note: CPSC was alerted to this hazard by the state of Wisconsin.



Canada Drawstring - Recall

HAZARD: Drawstring poses an entrapment hazard.

- The cotton hoodie has a waist drawstring that could pose an entrapment hazard to children.



FLOAT THREADS, THREAD ENDS & SPLICE YARNS

Float Threads

Concealed float threads and thread ends on footed garments, socks or mittens present the risk of becoming wrapped around fingers or toes causing loss of blood circulation.

Infants are more susceptible to this potential injury due to the inability to communicate the cause for discomfort.

Float Thread

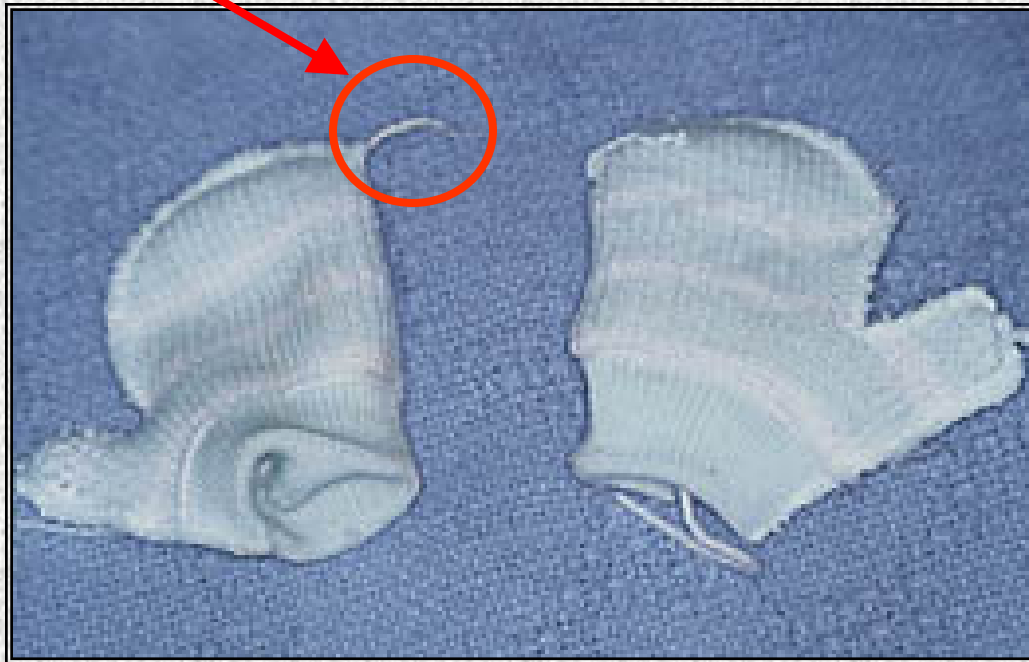

Two fingers of a 6-week-old infant were noted to be discolored, "black and red," following removal of mittens that had been placed on both hands 48 hours earlier to prevent scratching of the face by his fingernails. The infant had exhibited no unusual fussiness or irritability during this time.

Float Threads - USA

| | |
|--|--|
| Socks, Booties, or Footed Garments (0-6M) | |
| Foot Area | <i>Not permitted</i> |
| Non-Foot Area | ½ inch (1.27 cm) maximum length |
| Mittens | |
| Hand / Finger Area | <i>Not permitted</i> |
| Other Areas | |
| <i>(other than foot or hand area)</i> | ½ inch (1.27 cm) maximum length |

Float Threads - Canada

| Float Threads | 0-24 months | 2-18 |
|--|---------------------|----------------------------------|
| Foot / Toe area – Socks, Booties, Footed Garments | NO | 1/2 in (+/- 1/8 in) (1.27 cm) |
| Hand / Finger area – Mittens / Gloves | NO | 1/2 in (+/- 1/8 in) (1.27 cm) |
| All other areas –Socks, Booties, Footed Garments, Mittens and Gloves | 3/8 in (+/- 1/8 in) | 1/2 in (+/- 1/8 in) (1.27 cm) |

Thread Ends - USA

| | |
|---|----------------------------------|
| | 0-6 months |
| <u>Toe Seaming Threads</u> - Socks, Booties, or Footed Garments (toe area) | 3/4 in (+/- 1/8 in) (1.91 cm) |
| <u>Thread Ends</u> – All other areas –Socks, Booties, Footed Garments, Mittens and Gloves | 3/4 in (+/- 1/8 in) (1.91 cm) |

n **For footed garments, socks, or booties intended for sizes 0-6M, with a seam around the sole, the start / stop position must be in the ankle area to prevent seaming thread ends in the toe area.**

Thread Ends - Canada

| | 0-24 months | 2-18 |
|---|----------------------------------|----------------------------------|
| <u>Toe Seaming Threads</u> - Socks, Booties, or Footed Garments (toe area) | 1/4 in (+/- 1/8 in) (.64 cm) | 3/8 in (+/- 1/8 in) (.95 cm) |
| <u>Thread Ends</u> – Mittens / Gloves (finger area) | 1/4 in (+/- 1/8 in) (.64 cm) | 3/8 in (+/- 1/8 in) (.95 cm) |
| <u>Thread Ends</u> – All other areas –Socks, Booties, Footed Garments, Mittens and Gloves | 1/2 in (+/- 1/8 in) (1.27 cm) | 5/8 in (+/- 1/8 in) (1.59 cm) |

PRESS FASTENERS

Press Fasteners

n **Plastic Press Fasteners must be pre-applied to twill tape and be from an approved trim supplier.**



n **Press fasteners are not allowed at the knee area or any other area that could cause injury or discomfort on Sizes 0-5T (USA) and 0-6X (Canada).**

Examples of Press Fasteners



Press Fasteners – Approved Trim Suppliers

n **Press Fasteners must be from an approved source, as listed below:**

- **YKK (Universal Fasteners, Stocko, Newmax)**
- **Prym**
- **Scovill Fasteners Inc.**
- **Morito (Kane-M and Compass only)**
- **Mississippi Trading Company (MTI)**

n ***National Brands are exempt provided all product requirements are met as stated in the manual or as required by law.***

ZIPPERS

Zippers

- n **Invisible / concealed zippers are not allowed for Sizes 0-5T (USA) and 0-6X (Canada).**



- n **Stops designed so that zipper sliders can be removed are not allowed for Sizes 0-5T (USA) and 0-6X (Canada).**



Zippers

n **Zippers on children's apparel sizes 0-18 which include metal teeth, or a metal top or bottom stop require a zipper guard or facing to prevent the zipper from coming in direct contact with the skin. (not required for metal zipper components which do not come in direct contact with skin)**



Zipper Pulls

n **Indirect Attachment Pulls (2-piece zipper pulls)**

NOT allowed for sizes 0-5T (USA) and 0-6X (Canada).



n **Ring Pulls or other Open Type Designs**

Are allowed for Sizes 4 and up providing the inside (at widest point) ***DOES NOT EXCEED 1 INCH (2.54 cm)***.

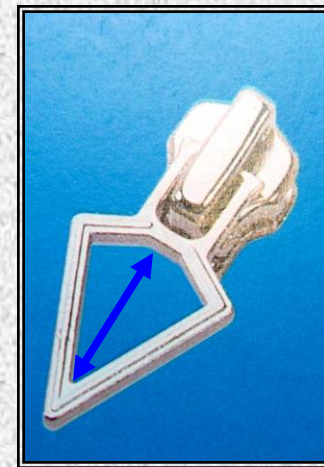
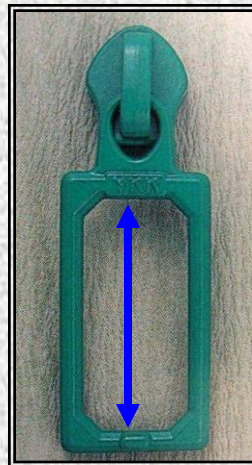

Zipper Pull Attachments



| | 0-5T USA 0-3X Canada | USA: Girls: 4-6X Boys: 4-7 4X-6X Canada | USA: Girls: 7-20 Boys: 8-20 7-18 Canada |
|-----------------------------------|-------------------------|--|--|
| Elastic Pulls | Not Permitted | Not Permitted | Permitted (cannot exceed 1 inch (2.54 cm) in length in the relaxed state) |
| Looped Pulls | Not Permitted | Not Permitted | Permitted |
| Plastic & Rubber Pulls | Not Permitted | Permitted | Permitted |

Zipper Pull Attachments – Maximum Length

| Position of Pull Attachment | Max. Length |
|--|-----------------|
| At the ends of long skirts or trousers | 1 in (2.54 cm) |
| At the ends of long sleeves | 1 in (2.54 cm) |
| At center plackets | 1½ in (3.81 cm) |
| All other locations | 2 in (5.08 cm) |

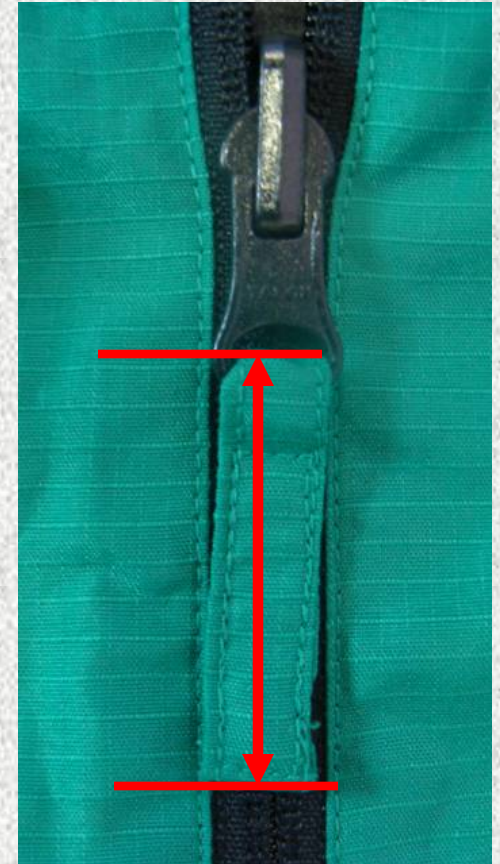

Zippers – Approved Trim Suppliers

n Zippers must be sourced as a complete unit from an approved source, as listed below:

- YKK
- Ideal Fasteners
- Talon Zippers (USA)
- HHH
- SBS (Canada)

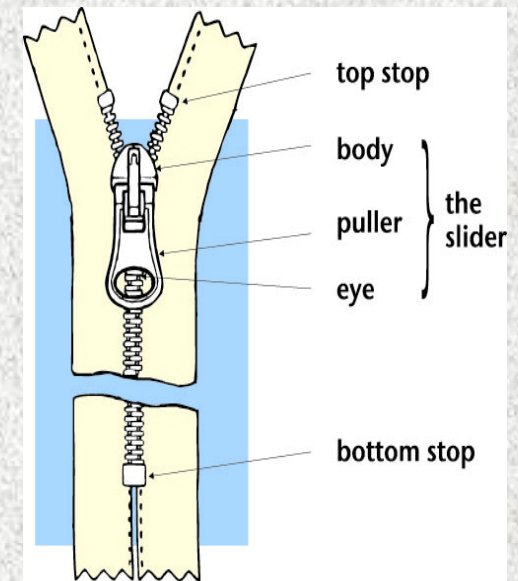

n *National Brands are exempt provided all product requirements are met as stated in the manual or as required by law.*

**DUNGAREE CLIPS
&
D-RINGS**

Dungaree Clips (Hasps) & Sliders

- n **For Sizes 0-5T (USA) & 0-6X (Canada), the dungaree clip (hasp) unit and construction of the strap and slider must be designed so that they cannot become detached from the garment.**
- n **There must be no visible joins on either the dungaree clip (hasp) or slider. All joins must be securely covered with fabric.**



Dungaree Clips (Hasps) and Sliders – Approved Trim Suppliers

n **Dungaree Clips (hasps) and Sliders must be from an approved source, as listed below:**

- YKK**
- Prym**
- Mississippi Trading Company (MTI)**

n ***National Brands are exempt provided all product requirements are met as stated in the manual or as required by law.***

D-Rings

- n D-Rings are **NOT** allowed for Sizes 0-5T (USA) & 0-3X (Canada).
- n D-Rings are **NOT** allowed at the end of ties with free ends.
- n There must be no visible joins in a D-Ring.
- n All joins must be securely covered with fabric.
- n D-Rings must be designed so that they cannot become detached from the garment.



BOWS & LOOPS

Fixed Bows

- n Bows must be securely attached at or near the center.
- n Tail ends of bows must be secured with double turn secured with a lockstitch, a heat seal, or a laser cut.
- n Length restrictions apply for loops and tails, depending on size of garment and bow location.

Total loop and tail lengths of a bow are measured:

From the exit point

OR

From the bartack

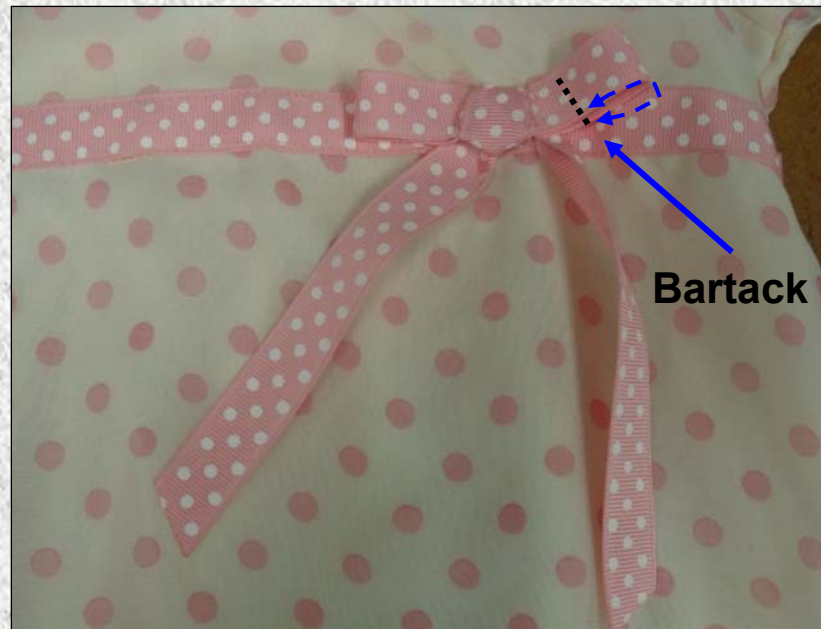

Functional and Decorative Loops

n **Fixed loops that protrude from garments must not exceed 3 inches (7.62 cm) in total circumference when measured end to end.**

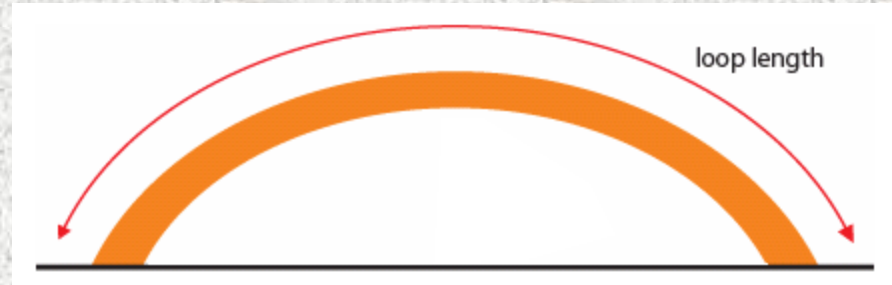

- **Hanger Loops are not allowed for Sizes 0-5T (USA) & 0-3X (Canada).**
- **Hanger Loops for Sizes 4 and up must be constructed of clear elastic tape which must break under the weight of the child.**

SASHES & BELTS

Sashes

A Sash is a fabric band permanently sewn into the side seams at the waist area of a dress or top which is intended to be tied in the back.



Sashes for sizes 0-5T (USA) & 0-3X (Canada):

- **Must measure at least 1.25 inches (3.18 cm) in width.**
- **Must not hang below the hem of the garment when untied.**
- **Must be permanently and securely attached at the waist area so that they cannot be removed.**
- **The length of all Sashes when untied must not exceed 14 inches (35.56 cm) (measured from the point where they are to be tied).**

Sashes & Thin Ties – Sizes 4 & up

Sashes and Thin Ties for sizes 4 and up:

- **Must be permanently and securely attached at the waist area so that they cannot be removed.**
- **The length when untied, must not exceed 14 inches (35.56 cm) (measured from the point where they are to be tied).**
- **It is recommended that tops and dresses include loops near the center back so if the ties or sashes are untied they do not hang below the hem of the garment.**



Belts with Buckles

n Buckles and D-Rings are *NOT permitted* on permanently attached belts intended for sizes 0-5T (USA) & 0-3X (Canada).

n Buckles and D-Rings *are permitted* on non-attached fabric belts intended for sizes 0-5T (USA) & 0-3X (Canada), provided the strap end of the belt does not exceed 3 inches (7.62 cm) in length.

n The strap end of buckled belts intended for the USA sizes 4-20 (girls) and 4-20 (boys) and the Canada sizes 4-18 must not exceed 5 ½ inches (13.97 cm) in length (applies to both attached or non-attached belts).

n The strap is measured from where the strap exits the buckle to the end.

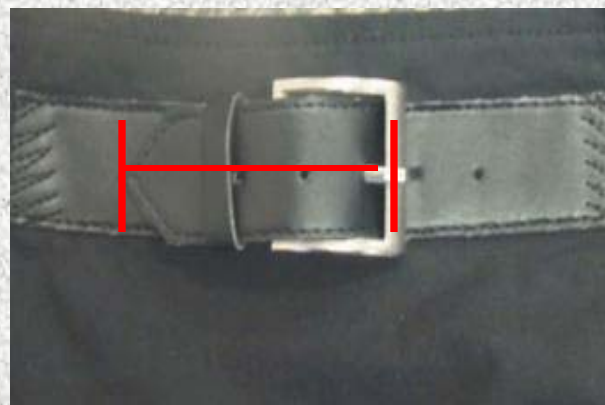

Belts without Buckles

Attached Belt (without Buckle)

- n The length of the belt when untied must be no more than 14 inches (35.56 cm) (measured from the point where the belt is to be tied).
- n Belts for sizes 0-5T (USA) & 0-3X (Canada) must not hang below the hem of the garment when untied (measured from the last belt loop).
- n It is recommended that tops, dresses and robes for sizes 4-18 include loops so if belt ends are untied they do not hang below the hem of the garment.



Belt attached at center back

Belts without Buckles

Non-Attached Belt (without buckle)

- n The length of the belt, when untied, must be no more than 14 inches (35.56 cm) for all USA sizes and Canada sizes 4-18 and no more than 7 inches for Canada sizes 0-3X (measured from the point where the belt is to be tied).



TOGGLES & BUTTONS

Toggles and Toggle Buttons

n **Toggles for Sizes 0-5T (USA) & 0-6X (Canada) must not be constructed of wood, cork, leather, mother of pearl (shell), glass or other non-durable material.**

n **Loops used to attach Toggle Buttons must be securely bartacked as close to the button as possible, while still being functional.**



n **Loops used to attach Toggle Buttons must not exceed 3 inches (7.62 cm) in total circumference.**



Buttons

- n **Buttons for Sizes 0-5T (USA) & 0-6X (Canada) must not be constructed of wood, cork, leather, mother of pearl (shell), glass or other non-durable material**



- n **Two-piece multi-component buttons or fabric covered buttons are not allowed for Sizes 0-5T (USA) & 0-6X (Canada)**



- n **Spare Buttons are not allowed for Sizes 0-5T (USA) & 0-6X (Canada)**

- n **Buttons for Sizes 0-5T (USA) & (Canada) must be attached using a lockstitch button attach machine**

**DECORATIVE TRIMS
&
EMBELLISHMENTS**

Decorative Trims & Embellishments

- n **Beads and Jewels are not allowed for Sizes 0-5T (USA) & 0-3X (Canada).**
- n **Beads and Jewels on Sizes 4 and up cannot be made of metal, glass or wood.**
- n **Sequins for USA Sizes 0-5T must be stitched at 5 points around each sequin.**
- n **Sequins are not permitted for Canada Sizes 0-3X**
- n **Sequins must not be constructed of metal.**
- n **Sequins for Sizes Girls 4-6x / Boys 4-7 must have the choking hazard warning.**
- n **Diamantes (Rhinestones) and Metal Studs are not allowed for Sizes 0-5T (USA) & 0-3X (Canada).**

Decorative Trims & Embellishments – Pom-poms

- Pom-poms must not be attached to the ends of drawstrings, cords or ties with free ends.
- Pom-poms and fringe must not be made with metal components.
- Traditional Pom-poms and fringe made from hand knitting/sweater yarns are not allowed on children's apparel sizes 0-5T (USA) & 0-3X (Canada).



Decorative Trims & Embellishments – Natural Feathers

- Natural Feathers are **NOT** allowed for any part of the *exposed* make-up of children's wearing apparel.
- Boas made of Natural Feathers are **NOT** allowed.



Natural Feathers

- **Feathers used on Caps and Hats are acceptable.**



- **Feathers contained within fabric, or filled, as in outerwear, are acceptable.**



ACCESSORIES & MISCELLANEOUS REQUIREMENTS

Halter Neck Style Garments, Baby Bibs & Neck Ties

- Halter Neck Style garments and Baby Bibs must not be constructed with free ends in the hood and neck area.



- The use of hook and loop tape, self fabric, snap fasteners and buttons are recommended for alternative fastening methods.



- Neck Ties for Sizes 0-5T (USA) & 0-3X (Canada) must be designed so that they detach or break away under the weight of the child.

Hat Closures

Under-Chin Ties

- **Allowed only on occasion wear (such as religious clothing).**
- **Must not exceed 8 inches (20.32 cm) in length, when measured from the point of securement.**
- **Must not be constructed of elastic.**
- **Must not exhibit trims, pom-poms, tassels, or other types of decorative trims attached to the ends.**



Hat Closures

Under-Chin Straps

- Allowed as long as they fit snugly against the chin and do not include pom-poms, tassels, or similar types of decorative trims.



Miscellaneous Requirements

- n ***Metallic Yarns and other Abrasive Materials*** are not allowed for use in garments designed for children 0- 9 months.



- n ***Pairing Clips and Thread Packaging Tacks*** are *NOT* allowed on socks and mittens designed for Sizes 0-5T (USA) & 0-6X (Canada).



Miscellaneous Requirements

- n ***Monofilament Thread*** is not allowed for use on children's apparel unless it is properly covered with a backing.
- n ***Boys Swim Short Liners*** must be made from micromesh fabric with a minimum of 225 holes per square inch.



Stitch Types













The following slides are acceptable stitch types for Walmart products. These guides can be found on retail link at the following link:

https://retailink.walmart.com/rl_docs/adp/ENG/18E48EC0C32349848DBC8DB66ACAF02E.pdf

Stitch Types

GLOSSARY OF STITCH TYPES















The recommended stitches per 2.5cm/1 inch are to be used as a guide only. The functionality of the seam, fabric type, required seam strength, seam extension and thread tension should all be considered when setting up the machine.

| Stitch name | ISO number | Top side of stitch | Underside of stitch | Minimum stitches per 2.5cm/inch |
|-----------------------------------|------------|--|--|--|
| Blindstitch | 103 |  | No stitch visible on outside or bottom of sewn product | 3–5 stitches |
| Lockstitch | 301 |  |  | 10–15 lightweight fabric 6–10 heavyweight Fabric |
| Twin needle lockstitch | 301 |  |  | 10–15 lightweight fabric 6–10 heavyweight Fabric |
| Multi-needle lockstitch | 301 |  <i>Multiple rows of this stitch</i> |  <i>Multiple rows of this stitch</i> | 10–15 lightweight fabric 6–10 heavyweight Fabric |
| Zig-zag lockstitch | 304 |  |  | 10–15 lightweight fabric 6–10 heavyweight Fabric |
| Lockstitch button sew | 304 |  | | Choice of 6, 8, 12, 16, 24 and 32 set cycle per button |
| Lockstitch buttonhole – Keyhole | 304 |  | | Depending of size of buttonhole & cover required |
| Lockstitch buttonhole – Fish tail | 304 |  | | Depending of size of buttonhole & cover required |
| Lockstitch buttonhole Slot | 304 |  | | Depending of size of buttonhole & cover required |

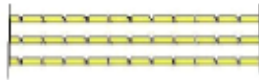
Stitch Types

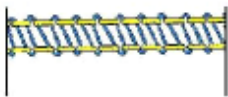
GLOSSARY OF STITCH TYPES















The recommended stitches per 2.5cm/1 inch are to be used as a guide only. The functionality of the seam, fabric type, required seam strength, seam extension and thread tension should all be considered when setting up the machine.

| Stitch name | ISO number | Top side of stitch | Underside of stitch | Minimum stitches per 2.5cm/inch |
|--|------------|--|--|---|
| Bartack | 304 |  | | Depending on length and width of tack |
| Chainstitch | 401 |  |  | 10–15 lightweight fabric 6–10 heavyweight fabric |
| 2 needle chainstitch | 401 |  |  | 10–15 lightweight fabric 6–10 heavyweight fabric |
| Multi-needle Chainstitch | 401 |  <i>Multiple rows of this stitch</i> |  <i>Multiple rows of this stitch</i> | 10–15 lightweight fabric 6–10 heavyweight fabric |
| 2 needle bottom coverstitch | 406 |  |  | 12–16 depending on desired appearance |
| 3 needle bottom coverstitch | 407 |  |  | 12–16 depending on desired appearance |
| 2 needle, 4 thread, top and bottom coverstitch | 602 |  |  | 12–16 depending on desired appearance |
| 3 needle, 4 thread, top and bottom coverstitch | 605 |  |  | 12–16 depending on desired appearance |

Stitch Types

GLOSSARY OF STITCH TYPES

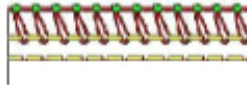
The recommended stitches per 2.5cm/1 inch are to be used as a guide only. The functionality of the seam, fabric type, required seam strength, seam extension and thread tension should all be considered when setting up the machine.

| Stitch name | ISO number | Top side of stitch | Underside of stitch | Minimum stitches per 2.5cm/inch |
|--|------------|---|---|---|
| 4 needle, 6 thread – <i>Flatlock</i> | 607 |  |  | 12–16 depending on desired appearance |
| 2 thread overlock | 503 |  |  | 10–15 lightweight fabric 6–10 heavyweight Fabric |
| 3 thread overlock | 504 |  |  | 10–15 lightweight fabric 8–12 heavyweight Fabric |
| 3 thread overlock, double purl | 505 |  |  | 10–15 lightweight fabric 8–12 heavyweight Fabric |
| Mock safety stitch | 512 |  |  | 10–15 lightweight fabric 8–12 heavyweight Fabric |
| 4 thread overlock | 514 |  |  | 10–15 lightweight fabric 8–12 heavyweight Fabric |
| 5 thread safety stitch | 516 |  |  | 10–15 lightweight fabric 8–10 heavyweight Fabric |

RESTRICTED & HAZARDOUS SUBSTANCES



RESTRICTED & HAZARDOUS SUBSTANCES



- Metal components that are located on a garment where it can come in direct contact with the skin must comply with the European Nickel Directive (94/27/EC).
- The requirement for nickel release for metallic components must not exceed 0.5 $\mu\text{g}/\text{cm}^2/\text{week}$ when tested in accordance with EN 1811 Reference Test Method for Release of Nickel from Products Intended to Come into Direct and Prolonged Contact with the Skin.

RESTRICTED & HAZARDOUS SUBSTANCES

Formaldehyde (USA)

Formaldehyde level for children's garments must not exceed:

| | |
|-------------------|---------------|
| Sizes 0-5T | 20 ppm |
| Sizes 4-20 | 75 ppm |

PVC in Baby Bibs

- Polyvinyl chloride (PVC) is NOT allowed for construction of baby bibs.

RESTRICTED & HAZARDOUS SUBSTANCES

Liquid Filled Products

- **Liquid filled accessories and embellishments must not contain hazardous liquid chemicals in accordance with requirements of 16CFR 1500.231 (USA) & Item 8, Part 1 Schedule of the HPA (Canada)**

- **Liquid filled accessories and embellishments must comply with USP 61 Microbial Limit Tests.**

Liquid Filled Product - Recall

Hazard: The liquid in the patches contained petroleum distillates which can be harmful if the bubble patch leaks or is punctured and the liquid is ingested.

NEWS from CPSC

U.S. Consumer Product Safety Commission

Office of Information and Public Affairs

Washington, DC 20207

FOR IMMEDIATE RELEASE

August 31, 1999

Release # 99-165

Company Phone Number: (800) 347-1466

CPSC Consumer Hotline: (800) 638-2772

CPSC Media Contact: Nychelle Fleming, (301) 504-7063

CPSC, GUESS? Inc. Announce Recall of Liquid-Filled Bubble Patch Girls' T-Shirts

WASHINGTON, D.C. - In cooperation with the U.S. Consumer Product Safety Commission (CPSC), GUESS? Inc., of Los Angeles, Calif., is recalling about 78,000 liquid-filled bubble patch t-shirts. The liquid in the vinyl bubble patch contains a petroleum distillate. If the bubble patch is punctured or leaks, the petroleum distillate can be harmful if ingested.

CPSC and GUESS? are not aware of any injuries involving these t-shirts. This recall is being conducted to prevent the possibility of injuries.

These girls' t-shirts have vinyl bubble patches in three different shapes: a heart, a circle and a rectangle. The heart-shaped bubble measures about 4 inches by 3 inches, has the "GUESS girl!" logo in blue frost, blue bell or red, and contains liquid and glitter. The round-shaped bubble patch, about 4 inches in diameter, has a red heart inside the circle, and is surrounded by blue liquid with the GUESS logo. Two rectangular patches containing dual color liquid of either yellow and blue or purple and blue, with the GUESS logo in black lettering. All the logos are applied to the front of various colored t-shirts. The collar label reads, "GUESS? girls" or "GUESS USA." They were sold in girls sizes small through extra large.

GUESS? Inc. and other clothing stores nationwide sold the t-shirts from June 1997 through March 1999 for \$10 to \$26, depending on the style.

Consumers should immediately stop wearing these t-shirts, and return them to the store where purchased for a refund. For more information, call GUESS? at (800) 347-1466 between 7:30 a.m. and 4:30 p.m. PDT Monday through Friday, or write to GUESS? Inc., 1444 South Alameda St. Los Angeles, CA 90021, (ATTN: Customer Service Dept.).



Heavy Metal Requirements for Child Care Articles

- Walmart has adopted standards and test methods based on EN 71-3 for heavy metals in child care articles.
- The following table outlines the requirements for the soluble limit in surface coatings:

| Restricted Substances for Child Care Articles, Toys, Children's Costume Jewelry & Children's Jewelry-Making Craft Kits | | | | | | |
|--|---------|----------|---------|----------|---------|----------|
| Soluble Limit for Surface Coatings | | | | | | |
| Antimony | Arsenic | Barium | Cadmium | Chromium | Mercury | Selenium |
| 60 ppm | 25 ppm | 1000 ppm | 75 ppm | 60 ppm | 5 ppm | 500 ppm |

Heavy Metal Requirements for Child Care Articles

- The following table outlines the **new** requirements for the soluble limit in substrate components:

| New Restricted Substances for Child Care Articles, Toys, Children's Costume Jewelry & Children's Jewelry-Making Craft Kits | | | | | |
|---|----------------|-----------------|----------------|-----------------|-----------------|
| Soluble Limit for Substrate Components | | | | | |
| Antimony | Arsenic | Barium | Cadmium | Chromium | Selenium |
| 60 ppm | 25 ppm | 1000 ppm | 75 ppm | 60 ppm | 500 ppm |

RESTRICTED & HAZARDOUS SUBSTANCES

➤ TOXICS IN PACKAGING (USA)

Toxics in Packaging Legislation was developed in 1989 to reduce the amount of heavy metals (lead, mercury, cadmium and hexavalent chromium) in packaging and packaging components. As of July 2004, legislation has been adopted by nineteen states. Walmart requires the Toxics in Packaging requirement for all of the USA.

➤ Information Resource: Toxics in Packaging Clearinghouse website:

<http://www.toxicsinpackaging.org>

CONSUMER PRODUCT SAFETY IMPROVEMENT ACT

“CPSIA”

NOTE: Applicable to the USA only

➤ ***WHAT IS THE CPSIA?***

- **The Consumer Product Safety Improvement Act of 2008 (CPSIA) is a new United States law, signed into effect August 14, 2008.**
- **The law is intended to better regulate consumer products and protect children from unsafe products by creating new authorities and increasing funding.**

➤ ***HOW DOES IT AFFECT CHILDREN'S PRODUCTS?***

- **Lowers Lead Limit - All children's products**
- **Restricts Phthalates - Certain Children's Products**
- **Mandatory Third Party Testing by Accredited Laboratories**
- **General Certificates of Conformity (GCC)**
- **Mandatory Tracking Labels**

➤ **WHAT IS A CHILDREN'S PRODUCT?**

- **Children's Product** - a consumer product designed or intended ***primarily*** for children under 12 years of age.
- **Children's Toys** - items with play value designed, marketed and intended for children that are under 12 years of age.
- **Other Articles Intended for Use by Children** - products that lack play value, but by design, marketing, or advertising are ***primarily*** intended to be used by children under 12 years of age.
- **Child Care Articles** - Consumer products designed, marketed, or intended to facilitate sleep or feeding for children less than 4 years of age, or to help such children with sucking or teething.

CPSC has ruled that certain children's apparel items will be regulated as child care articles if they facilitate sleep, feeding, sucking or teething.

Examples are pajamas, sleepers, and baby bibs.

➤ **WHAT IS A CHILDREN'S PRODUCT?**

- **Children's Apparel** - Apparel that is designed, marketed and intended for use by children under age 12.
 - Includes children's apparel sizes 0-20 (unless otherwise stated).
 - Includes apparel used for dress up, role play and costumes.

CPSIA - Information Resource:

Consumer Product Safety Commission Website: www.cpsc.gov

Information on the Consumer Product Safety Improvement Act (CPSIA)

The screenshot shows the CPSC Home Page in a Windows Internet Explorer browser window. The browser title is "CPSC Home Page - Windows Internet Explorer provided by Consumer Testing Laboratories". The address bar shows "http://www.cpsc.gov/". The browser interface includes a menu bar (File, Edit, View, Favorites, Tools, Help) and a toolbar with icons for home, search, and other functions. The main content area features a header with the CPSC logo and the text "U.S. Consumer Product Safety Commission". Below the header is a navigation bar with tabs for "Consumer Safety", "About CPSC", "Library - FOIA", and "Business". A green banner highlights the link "Information on the Consumer Product Safety Improvement Act (CPSIA)". A red arrow points from this link in the banner to the same link in the main content area. The main content area includes sections for "Recalls and Product Safety News", "Neighborhood Safety Network (Español)", "Report an Unsafe Product", "Product Safety Standards", "Sign Up for Email Announcements (Español)", and "CPSC Publications". A "Recent Recalls" section lists various products, including "Newborn and Infant Pants", "Heavy Duty Acidic Cleaner", "Candles", "Bead Maze Toys", "Window Blinds (Español)", "Roman Blinds (Español)", "Air Compressors", "Dive Sticks", and "Children's Hooded Jackets". An image of a pair of blue jeans is shown next to the "Newborn and Infant Pants" recall. The browser status bar at the bottom shows "Internet" and "100%".

CPSIA – Requirements

➤ LEAD IN SURFACE COATINGS

Scheduled reduction of limits on lead in surface coatings for *ALL* children's products.

- 90 ppm - offered for sale August 2009
(WM date was July 01, 2009)

Per the CPSIA, Lead requirements are retroactive and affect existing product, regardless of the date purchased, manufactured or shipped.

CPSIA – Requirements

➤ Lead - Surface Coatings

- **Surface coatings must be scraped from representative product samples.**

Wet paint is not acceptable for testing.

CPSIA – Requirements

➤ Lead – Surface Coatings:

All coatings must be tested for lead.



CPSIA – Requirements

➤ Lead – Surface Coatings:

Prints that are not bonded with the substrate must be tested.



This screen print
can be scraped
from the fabric.

CPSIA – Requirements

➤ Lead – Surface Coatings:

Prints that are not bonded with the substrate must be tested.



“Puff prints” are not bonded with the substrate

CPSIA –Requirements

➤ LEAD IN SUBSTRATES

Currently 300 PPM limit on total lead by weight in accessible substrates for *ALL* children's products.

- 300 ppm - Offered for sale Aug 2009 - (WM date July 01, 2009)
- 100 ppm - Offered for sale Aug 2011 - (WM date 01, July 2011)

Per the CPSIA, Lead requirements are retroactive and affect existing product, regardless of the date purchased, manufactured or shipped.

CPSIA – Requirements

➤ Lead – Substrates:

All substrates must be tested.



CPSIA – Requirements

➤ Lead – Substrates:

All component parts must be tested



CPSIA – Requirements

➤ Lead –Substrates:

All component parts must be tested





Examples of Substrates that are tested for lead



S-Hook



Button



Rhinestones



Embellishments

CPSIA –Requirements

➤ **PHTHALATES** - *New restrictions on phthalates for the following products:*

- **Child Care Articles**

Limit - 1000 ppm: DEHP, DBP, BBP, DINP, DIDP or DnOP

▪(Manufactured after Feb 10, 2009)

- **Mouthable Toys**

Limit - 1000 ppm: DEHP, DBP, BBP, DINP, DIDP or DnOP

▪(Manufactured after Feb 10, 2009)

- **All Other Toys**

Limit - 1000 PPM: DEHP, DBP or BBP

▪(Manufactured after Feb 10, 2009)

CPSIA –Requirements

➤ **PHTHALATES** - *Walmart also restricts phthalates in children's apparel*

- **Apparel**

Limit – 1000 ppm DEHP, DBP, BBP, DINP, DIDP, DnOP

(Effective for apparel manufactured on, or after August 14, 2009)

CPSIA – Requirements

Phthalates in Apparel: Applies to soft plastic components in apparel that are accessible to the mouth when worn. This applies to apparel that is marketed or intended for children less than 4 years of age which includes newborn, infant and toddler sizes 5T and under

Plastic Light
Up Patch
On
Toddlers
T-Shirt



Raised
Screen
Print on
Toddlers
Shirt



CPSIA – Requirements

Phthalates in Child Care Articles: Applies to plastic components used in products designed, marketed, or intended to facilitate sleep or feeding for children less than 4 years of age, or to help such children with sucking or teething.

The plastic surface on this bib must meet phthalate requirements.



Note: Walmart has banned bibs constructed with PVC.

CPSIA – Requirements

Phthalates in Child Care Articles: Applies to plastic components in products which are designed, marketed, or intended to facilitate sleep or feeding for children less than 4 years of age, or to help such children with sucking or teething.



The plastic sole material on this sleeper must meet phthalate requirements.



➤ CERTIFICATES OF CONFORMITY

- Suppliers must provide a General Certificate of Conformity (GCC) for products regulated by the CPSC.
- Certificates are to verify that each Children's Product meets requirements of all Rules, Bans, Standards or Regulations under Acts enforced by the CPSC.
- Certificates must accompany each shipment and be provided to Customs at port of entry.
- Effective for products manufactured on , or after November 12, 2008
- Some certificates can be supported by a reasonable testing program, however all children's products will eventually require testing by an accredited third party laboratory

➤ CERTIFICATES OF CONFORMITY

Certain products must be supported by testing documentation from an Accredited Third Party Laboratory.

Children's Apparel:

- **16 CFR 1610** – Flammability of Clothing Textiles - mandatory third party testing starts September 2009.
- **16 CFR 1611** – Flammability of Vinyl Plastic Film – mandatory third party testing starts September 2009.
- **16 CFR 1303** – Lead in Surface Coatings – mandatory third party testing starts December 2008
- **16 CFR 1615/1616** – Flammability of children's sleepwear – mandatory third party testing starts September 2009.
- **16 CFR 1500.48 and .49** – Sharp Points and Sharp Edges – mandatory third party testing starts September 2009

CPSIA – Requirements

➤ CERTIFICATES OF CONFORMITY - EXAMPLE

CERTIFICATION OF COMPLIANCE

1. Identification of the product
2. Citation to each CPSC safety regulation to which the product is being certified
3. Identification of the manufacturer certifying compliance of the product
4. Contact information for the individual maintaining records of test results
5. Date and place of manufacture
6. Date and place of testing for compliance with the cited regulation(s)
7. Identification of third-party laboratory on whose testing the certificate depends

CPSIA – Requirements

➤ TRACKING LABELS

All children's products manufactured on or after August 14, 2009 must have to the extent practicable, the following permanent marks on product and packaging.

- Manufacturer or private labeler name
- Location of production
- Date of production
- Other information
(batch, run number, sources)



➤ TRACKING LABELS

Tracking labels must be *permanent* where practicable.

**HANGTAGS ARE
NOT CONSIDERED
PERMANENT**

**SEWN IN LABELS ARE
PERMANENT**



➤ TRACKING LABELS

Tracking labels must be *permanent* where practicable.

**“TRANSFER”
LABELS
ARE PERMANENT**



CPSIA – Requirements

➤ WARNINGS FOR DIRECT SALE ADVERTISING

- **Toys and Games:**

Advertising that provides direct means of sale (website, catalogues) for a toy or game subject to choking hazard warning must include mandatory warning information.

- Obligation does not apply to general advertising. It only applies where there is a direct sale to the consumer.
- CPSC warnings must be posted December 12, 2008

See <http://www.cpsc.gov/businfo/frnotices/fr09/lrtgafin.pdf>

**Canada -
Hazardous Products Act & Surface Coating
Materials Regulations (SOR/2005-109)**

NEW:

- n **Effective June 1, 2010 the requirement for lead in surface coatings will be 90 ppm**

Walmart Canada's requirement for lead in accessible substrates is 600 ppm



All information contained in the above presentation is the sole property of Consumer Testing Laboratories, Inc. Copying, distribution or reuse of this information without prior written consent of Consumer Testing Laboratories, Inc. is prohibited.